

PROJECT		<b>Annual Report</b>	
<small>*CONFIDENTIAL - THIS DOCUMENT CONTAINS PROPRIETARY INFORMATION OF INTRICON CORPORATION. NOT TO BE USED FOR ANY PURPOSE UNAUTHORIZED BY INTRICON CORPORATION*</small>		<small>TOL. UNLESS OTHERWISE SPECIFIED          .XX ± .01          .XXX ± .005          .XXXX ± .0005          ANGLE: ± 1°</small>	
YEAR		<b>2010</b>	
MATERIAL	FINISH	DWG. NO.	REV
80 LB COVER	Smooth	INT80237	D05
Q1 Q2 Q3 Q4	DO NOT SCALE DRAWING	SCALE: 1:1	SHEET 2 OF 2

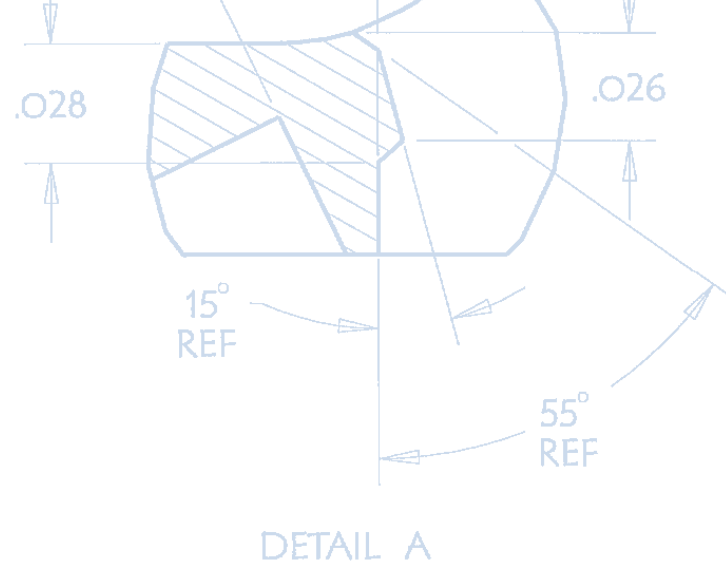

# Designing world-class products and technologies to enhance the world we live in.

## BODY-WORN DEVICES MADE SMALLER, BETTER CONNECTED AND MORE MOBILE.

IntriCon designs, develops and manufactures miniature and micro-miniature body-worn devices. These advanced medical and electronics products help meet the rising demand for smaller, better connected and more mobile devices.

Our expertise is focused on three main markets: medical, hearing health and professional audio communications. Within these chosen markets, we combine ultra-miniature mechanical and electronics capabilities with our proprietary technology—including ultra-low-power (ULP) wireless and digital signal processing (DSP) capabilities and miniature transducers—to enhance the mobility and effectiveness of miniature body-worn devices and ultimately, improving quality of life.

IntriCon is headquartered in Arden Hills, Minn., a suburb of Minneapolis/St. Paul. We employ more than 500 people at facilities in the United States, Europe and Asia. IntriCon common stock is traded on the NASDAQ Global Market under the symbol "IIN."

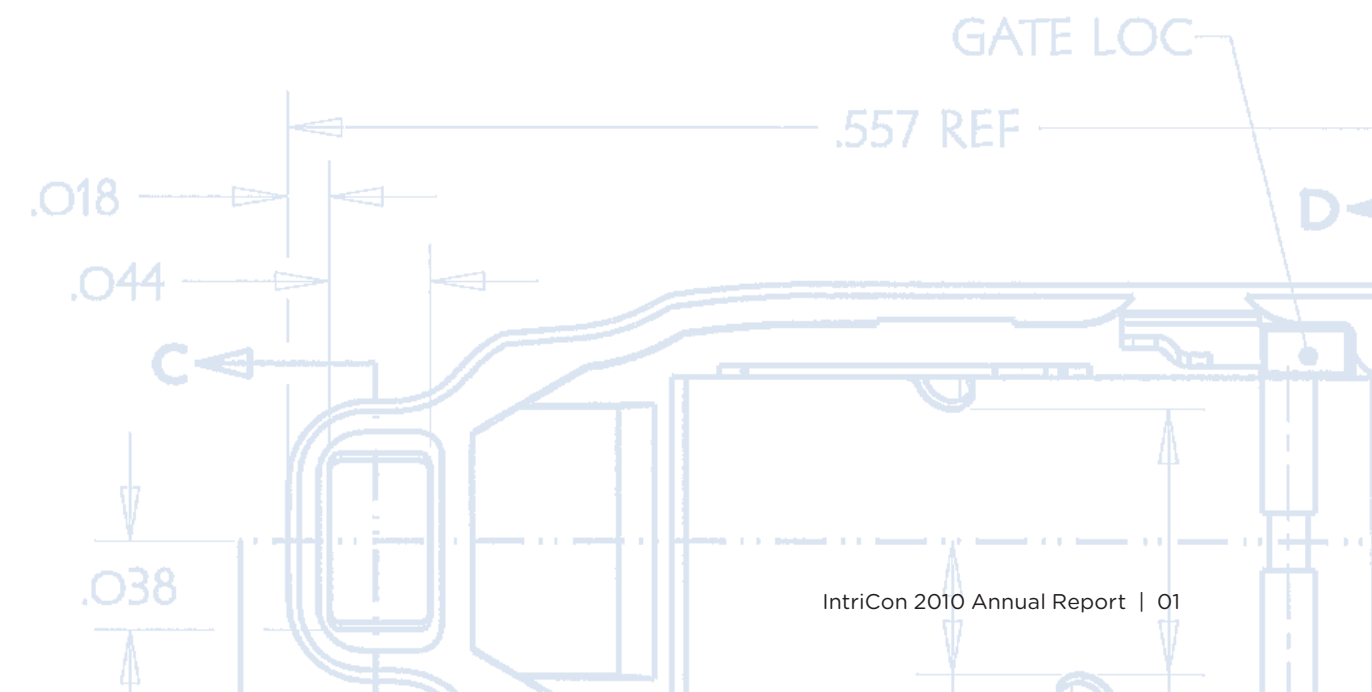
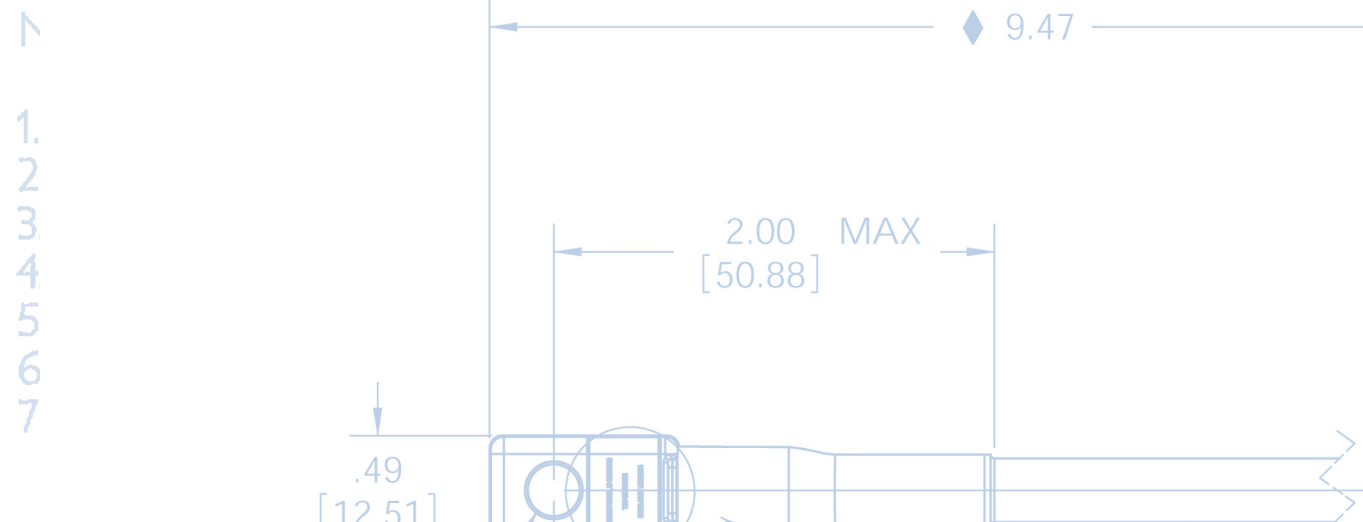

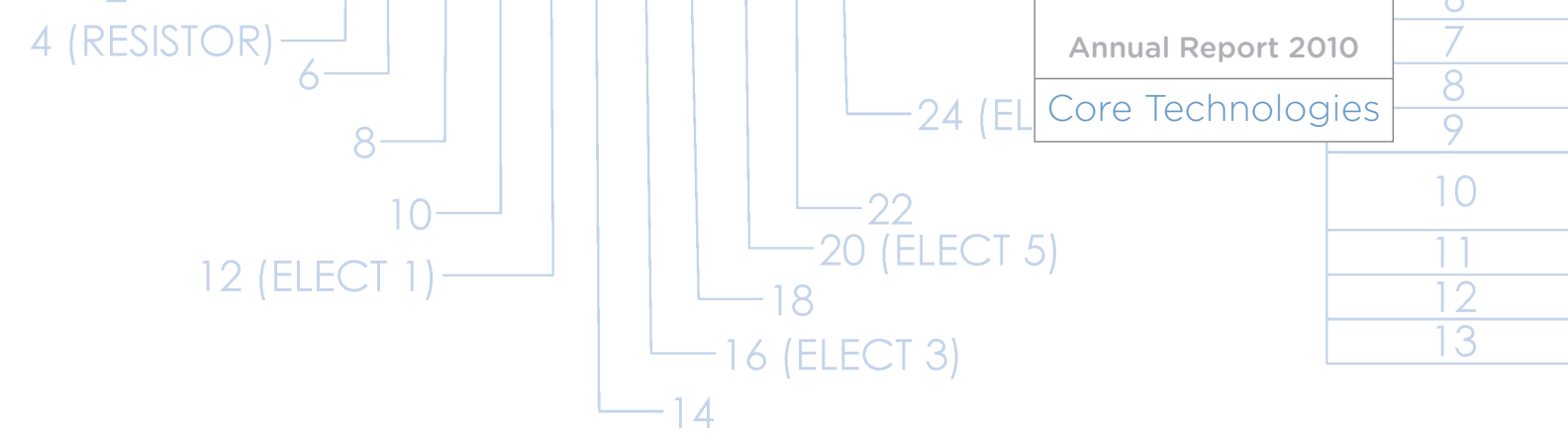
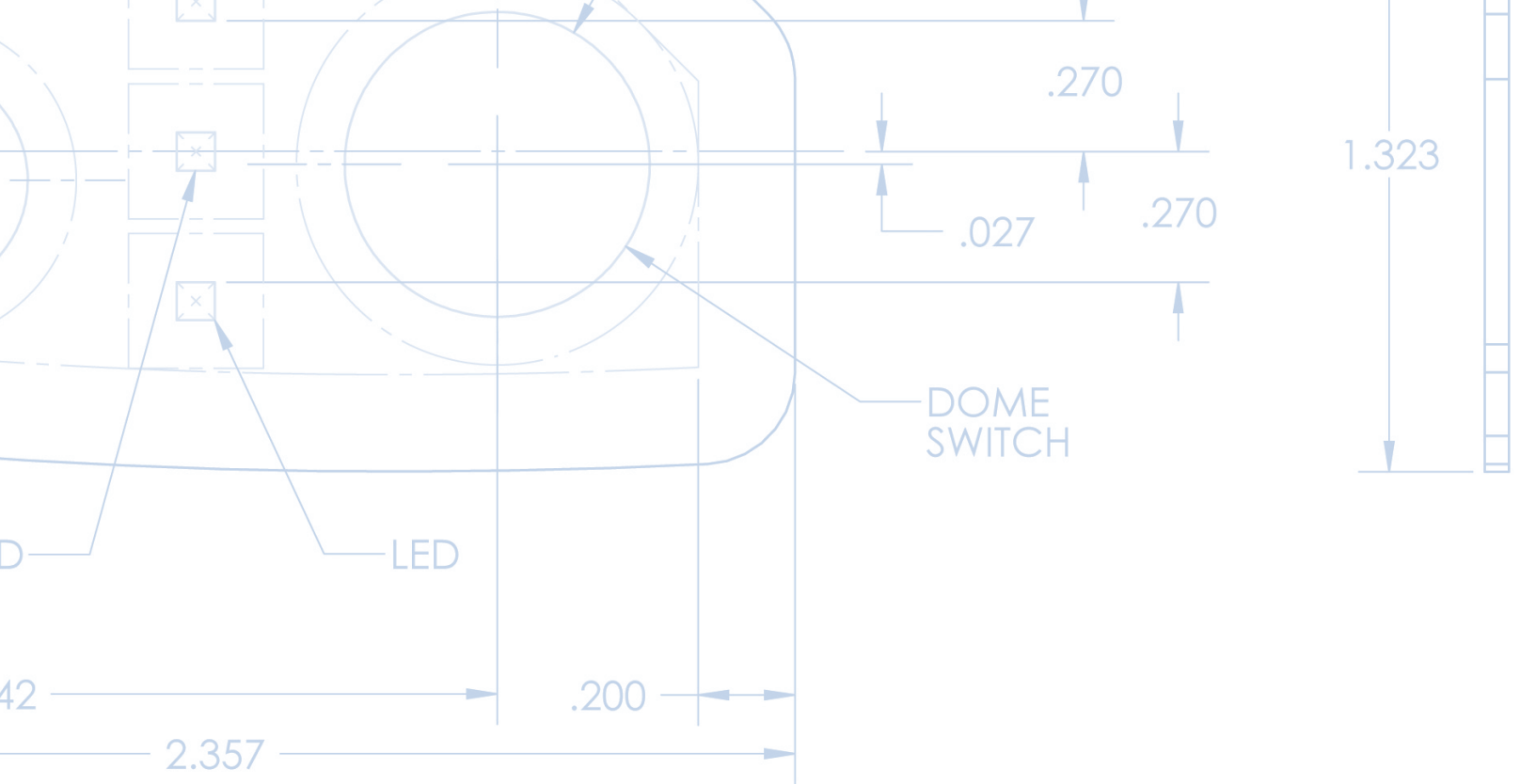

## Innovation drives us. TECHNOLOGY DEFINES US.

At IntriCon, our core technologies are our future. They help us make advanced body-worn devices that are smaller, better connected and more mobile. Created through countless hours of focused research and development, these proprietary technologies span all of our markets and serve as the foundation for advanced new devices that allow people to hear better, communicate with ease and receive exceptional medical care.

### Ultra-Low-Power Digital Signal Processing

Digital signal processing, or DSP, converts real-world analog signals into digital format. Through its nanoDSP® technology, IntriCon offers an extensive range of ultra-low-power (ULP) DSP amplifiers for hearing, medical and professional audio applications. Our proprietary nanoDSP incorporates advanced ultra-miniature hardware with sophisticated processing algorithms to produce devices that are smaller and more effective.

### Ultra-Low-Power Wireless Connectivity

Wireless connectivity is fast becoming a required technology—and wireless capabilities are especially critical in new body-worn devices. IntriCon’s BodyNet® ULP technology, including the nanoLink® and PhysioLink® wireless systems, offers solutions for measuring and transmitting the body’s activities to caregivers, as well as wireless audio links for professional communications and surveillance products. BodyNet applications include ECG diagnostics and monitoring, diabetes monitoring, sleep apnea studies and audio streaming for hearing aids.

### Miniaturization

At IntriCon, we are experts in *miniaturization*—in our world, smaller is better. Our core miniaturization technology allows us to make devices for our markets that are one cubic inch and smaller. We also are specialists in devices that run on very low power—as evidenced by our ULP wireless and DSP. Less power means a smaller battery—and this enables us to reduce size even further and develop devices that fit into the palm of a hand.

### Miniature Transducers

Our miniature microphone, receiver and micro coil technology has been pushing the limits of size and performance for more than a decade. This technology, which has been incorporated into various product platforms, enhances the reliability, sensitivity, supply voltage and output level in body-worn devices. These enhancements allow us to make devices that are extremely portable and perform well in noisy or hazardous environments, and are well-suited for applications in the medical, aviation, fire, law enforcement, safety and military markets. Our technology also is used for technical surveillance by law enforcement and security agencies, and by performers and production staff in the music and stage performance markets.



## Financial Highlights

(dollars in thousands, except per-share data)

Fiscal Year Ended December 31,	2010	2009	2008
Net sales	\$58,697	\$51,676	\$57,908
Gross profit	15,013	11,051	14,657
Gross profit percentage	25.6%	21.4%	25.3%
Research and development expense	4,485	3,345	3,248
Income (loss) from continuing operations	655	(1,802)	1,314
Net income (loss)	361	(3,921)	1,038
Diluted net income (loss) per share	0.07	(0.73)	0.19

At December 31,	2010	2009	2008
Cash	\$ 759	\$ 791	\$ 635
Working capital	8,615	8,504	10,602
Current liabilities	9,149	9,611	9,421
Funded debt	7,860	8,378	7,691
Shareholders' equity	18,571	17,489	20,312

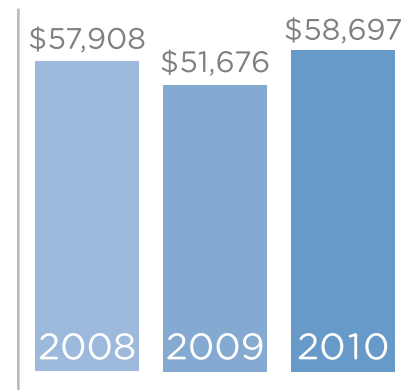

Net Sales

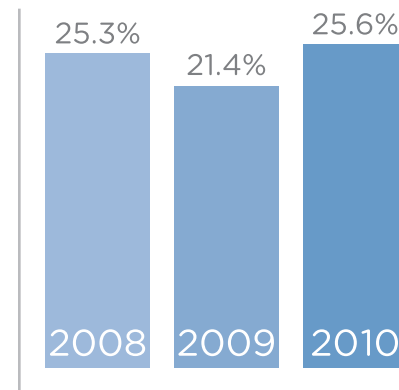

Gross Profit Percentage

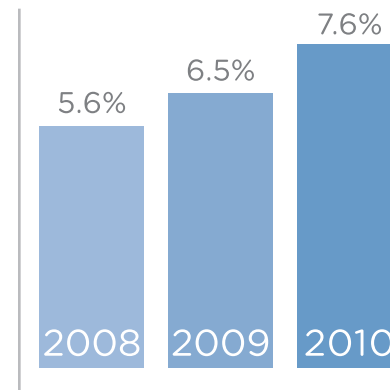

R&D as Percentage of Net Sales

## TO OUR SHAREHOLDERS

In 2010, we began to emerge from one of the most trying economic periods in recent history. Despite challenges, we continued to grow revenue—all three of our chosen markets posted year-over-year gains—and we were profitable for the year. Equally important, we enhanced our position for long-term growth through increased investments in research and development.

Across the board, we are focusing our resources and capital on our strengths: making body-worn devices smaller, better connected and more mobile. We're doing so by leveraging our proprietary core technologies and accelerating the development of new core technologies. We believe our continued prudent investments in these initiatives will fuel long-term growth.

We also made significant progress during the year in: developing our core technologies across multiple product platforms; launching new devices; and continuing to run an efficient organization.

Our strategy centers both on the concept of enhancing the mobility and effectiveness of existing devices, and creating entirely new technology-driven products.

As a company, we are channeling our expertise into three main markets: medical, hearing health and professional audio communications. However, our core technologies that drive our products offer potential benefits to many other industries—and it's our ultimate goal to reach a broader marketplace.



**Core Technologies Incorporated:**  
ULP DSP, ULP Wireless, Miniaturization



## 2010 Results

2010 was a strong year for IntriCon. We reported net sales of \$58.7 million and net income of \$361,000, or \$0.07 per diluted share. This was up from 2009 net sales of \$51.7 million and a net loss of \$3.9 million, or \$0.73 per diluted share. 2009 results included a loss from discontinued operations of \$2.1 million, or \$0.39 diluted share, and Datrix-related acquisition costs and bank financing charges of \$561,000, or \$0.10 per diluted share.

Our medical business represented 42 percent of total revenue in 2010, with hearing health and professional audio communications contributing 36 percent and 22 percent, respectively. This was relatively consistent with 2009 levels.

Gross profits for 2010 were 25.6 percent, up from 21.4 percent in 2009. These gains stemmed from higher sales volumes, increased proprietary technology in products—which generates higher margins—and the impact of profit enhancement programs, including production transfers to lower-cost manufacturing facilities and the ongoing rollout of lean manufacturing programs.

As a percent of 2010 sales, research and development (R&D) was 7.6 percent, up from 6.5 percent in 2009. R&D is the best investment that we can make in our future—and provides the needed foundation for a robust new-product pipeline. In addition, we had a significant amount of customer-funded R&D and technology licensed from Advanced Medical Electronics (AME) as a result of customer-funded grants, which greatly increased our IP portfolio.

## Medical

Medical was IntriCon's largest business in 2010. While growing a modest seven percent over the prior year, we continue to maintain strong relationships with our medical OEM customers. Moreover, we anticipate that this business will return to more historic growth rates in 2011 as temporary pauses in ordering abate.

In the medical arena, we continue to advance our new Centauri™ cardiac diagnostic monitoring (CDM) device. Centauri is a next-generation wireless outpatient monitoring device that uses a proven automatic arrhythmia detection algorithm. We anticipate securing FDA approval for Centauri in the second half of 2011.

We also premiered our PhysioLink™ wireless technology, which will be incorporated into products in the medical, hearing health and professional audio communication markets. This proprietary technology allows for wireless data links, which consume significantly less power than Bluetooth radios, resulting in more compact devices. The first product platform to incorporate the PhysioLink will be Sirona®, our second generation wireless CDM device.

In biotelemetry, we remain active with our strategic partner AME. AME specializes in the design of wireless systems, embedded systems and biomedical sensing applications. Their work is concentrated on grant-funded

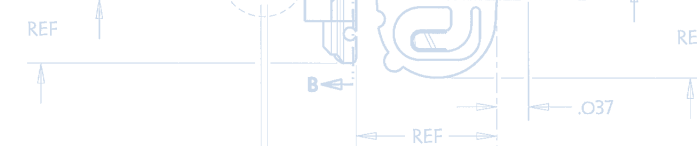

research for biomedical applications. Currently we are jointly working on 14 grant-funded projects related to wireless medical technology and wireless hearing aids. IntriCon holds licenses to this technology for the markets we serve.

## Hearing Health

Hearing health posted a 14 percent year-over-year gain in 2010. Driving the increase was the continued overall rebound in the hearing aid market, combined with pent-up demand. We believe that our recent new product introductions will lead to significant future growth.

During the year, we unveiled our hybrid Overtus™ DSP amplifier. Overtus is designed to: optimize open in-the-canal (ITC) fittings; utilize an advanced adaptive feedback canceller, Reliant CLEAR™; and incorporate AcousTAP™, an acoustic switch that eliminates the need for a bulky mechanical switch, allowing for further miniaturization. This amplifier uses two patent-pending technologies that allow our OEM customers to produce their own open in-the-ear devices.

As the amplifier component of hearing aids, Overtus brings significant technology advantages over existing devices. We've taken that technology and developed our own complete hearing device, the all-new, patent-pending APT™ Open ITC.

IntriCon is committed to developing hearing aids that bring proprietary enhancements to the marketplace. Research has shown that there are considerable negative social, psychological, cognitive and health effects associated with untreated hearing loss. Overtus and APT offer an effective means to address this condition.

## Professional Audio Communications

Professional audio communications grew 28 percent in 2010—the largest increase of our three markets. The substantial gain was from higher sales of headset devices to existing customers and communication devices to government agencies.

During the year, we continued to make progress developing our situational listening device (SLD) product line. Using our PhysioLink core technology, SLDs help people hear in noisy environments, allowing them to listen to television, music and direct broadcast by wireless connection. SLDs supplement conventional hearing aids that don't handle noisy situations well. We anticipate market trials of the SLD platform to start in the second half of 2011.

The same proprietary technology that we use in hearing health, including ULP wireless and DSP, holds tremendous potential for professional audio communications. In 2011, we intend to increase our core technology content in targeted product lines to further enhance performance and reduce the size of ear- and head-worn devices.



**Core Technologies Incorporated:**  
ULP DSP, Miniaturization

## APT™ Open ITC

The all-new patent-pending APT Open in the canal (ITC) hearing aid is powered by IntriCon's Overtus™ DSP amplifier and features the Reliant CLEAR™ adaptive feedback canceller and the AcousTAP™ acoustic push button. APT's design is so small it does not occlude a patient's ear canal and the replaceable wax guard system enhances APT's robust mechanical design. These unique features create stable and effective amplification, occlusion-free comfort and easy integration into existing fitting systems.

**SITUATIONAL LISTENING DEVICES**

**Core Technologies Incorporated:**

ULP DSP, ULP Wireless, Miniaturization, Miniature Transducers

**Situational Listening Devices**

SLDs help assist people to hear in noisy environments, allowing them to listen to television, music and direct broadcast by wireless connection. SLDs supplement conventional hearing aids that don't handle noisy situations well. As part of the SLD family, IntriCon will be offering a line of complementary accessories, including a companion microphone, television adapter and iPod adapter. The company anticipates conducting market trials of its SLD platform in the second half of 2011.

**Looking ahead**

In 2011, we plan to build on the initiatives that drove success in 2010: developing our core technologies across multiple product platforms; launching new devices; and continuing to run an efficient organization.

From a customer standpoint, we are committed to making body-worn devices smaller, better connected and more mobile. As a business, we are focused on building revenue, improving margins and growing our bottom line. We will do so by: driving higher sales volumes; raising the percentage of proprietary IntriCon technology we incorporate into our products; and increasing our low-cost manufacturing footprint.

On behalf of IntriCon's management and the board of directors, I would like to thank our customers for their loyalty, our team of employees for their contributions and our shareholders for their support.

Sincerely,



Mark Gorder  
President and Chief Executive Officer  
IntriCon Corporation  
March 15, 2011.

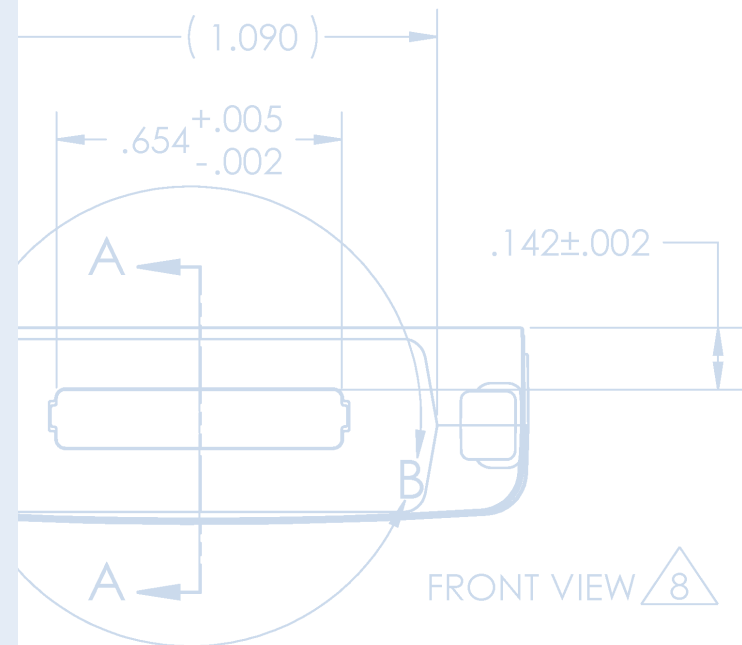

**Management**

**Mark S. Gorder**  
President and Chief Executive Officer

**J. Scott Longval**  
Chief Financial Officer, Secretary and Treasurer

**Christopher D. Conger**  
Vice President, Research and Development

**Michael P. Geraci**  
Vice President, Sales and Marketing

**Greg Gruenhagen**  
Vice President, Quality and Regulatory Affairs

**Dennis L. Gonsior**  
Vice President, Global Operations

**Directors**

**Michael J. McKenna**  
Chairman of the Board of IntriCon Corporation, Retired Vice Chairman, President and Director, Crown Cork & Seal Company, Inc.

**Nicholas A. Giordano**  
Business Consultant, Former President and Chief Executive Officer Philadelphia Stock Exchange

**Mark S. Gorder**  
President and Chief Executive Officer IntriCon Corporation

**Robert N. Masucci**  
Chairman of Barclay Brand Ferndon, Inc. Chairman, Montgomery Capital Advisors, Inc.

**Philip N. Seamon**  
President, Philip N. Seamon, Inc. Retired Senior Managing Director, Corporate Finance, FTI Consulting, Inc.

**Legal Counsel**

**Blank Rome LLP**  
Philadelphia, Pennsylvania

**Auditors**

**Baker Tilly Virchow Krause, LLP**  
Minneapolis, Minnesota

**Transfer Agent and Registrar**

**Stock Trans**  
44 West Lancaster Avenue  
Ardmore, Pennsylvania 19003  
stocktrans.com  
1.800.733.1121

**Locations**

**IntriCon Corporation Headquarters**  
1260 Red Fox Road  
Arden Hills, Minnesota 55112  
Phone: 651.636.9770  
Fax: 651.636.8944  
intricon.com

**IntriCon, Inc.**  
1260 Red Fox Road  
Arden Hills, Minnesota 55112

**IntriCon Datrix Corporation**  
340 State Place  
Escondido, California 92029

**IntriCon Tibbetts Corporation**  
5 Colcord Avenue  
Camden, Maine 04843

**IntriCon PTE LTD**  
Admirax, 8 Admiralty Street  
#02-01 to 06  
Singapore 757438

**IntriCon Gmbh**  
Kesselschmiedstr. 10  
D-75354 Freising, Germany

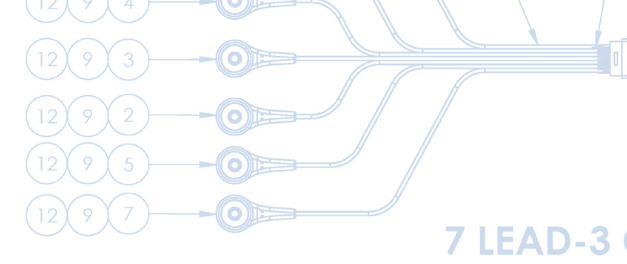

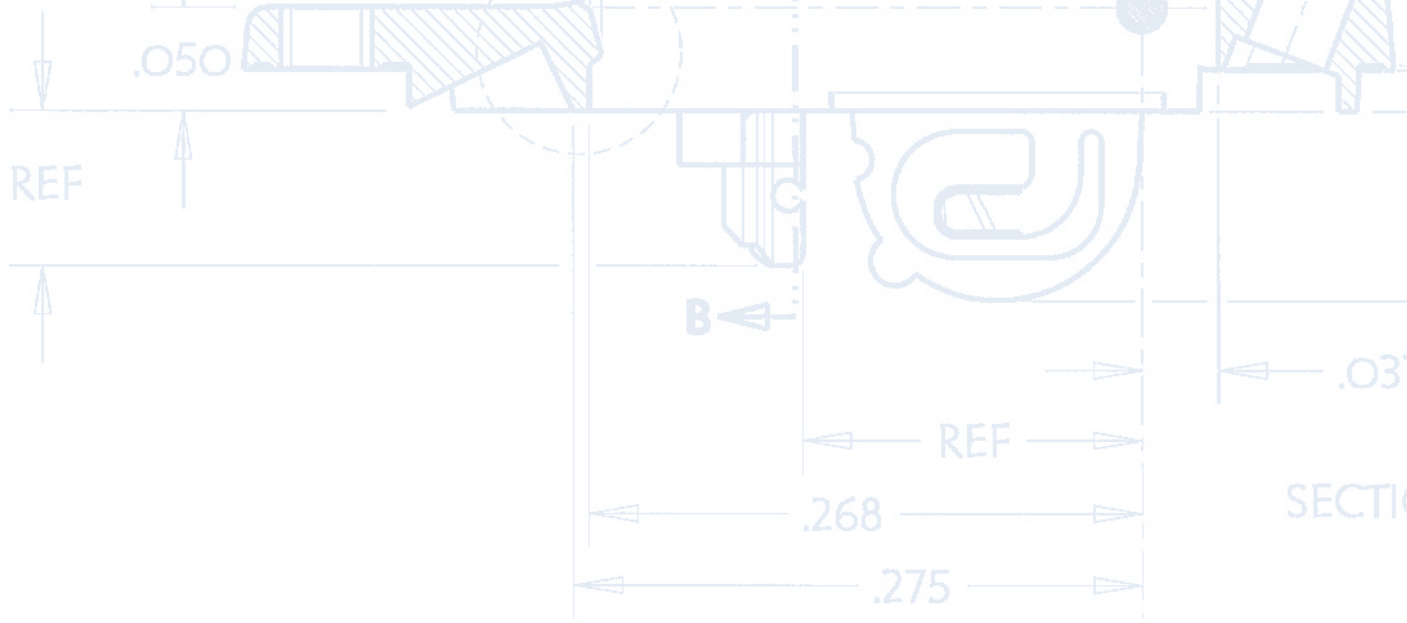

BODY-WORN DEVICES  
MADE SMALLER,  
BETTER CONNECTED  
AND MORE MOBILE.



IntriCon Corporation  
1260 Red Fox Road  
Arden Hills, Minnesota 55112

Phone: 651.636.9770  
Fax: 651.636.8944  
intricon.com